

**REVISITING
EUROPEAN
UNEMPLOYMENT**

**UNEMPLOYMENT,
CAPITAL ACCUMULATION
AND FACTOR PRICES**

Twenty Eighth Geary Lecture 1997

OLIVIER BLANCHARD

*Copies of this paper may be obtained from The Economic and Social
Research Institute (Limited Company No. 18269). Registered Office:
4 Burlington Road, Dublin 4, Ireland*

Price IR£8.00
ISBN 0 7070 0175 7

Professor Olivier Blanchard is the Class of 1941 Professor of Economics at the Massachusetts Institute of Technology. This paper has been accepted for publication by the Institute which is not responsible for either the content or the views expressed therein.

©1997 Olivier Blanchard. All rights reserved.

Revisiting European Unemployment: Unemployment, Capital Accumulation, and Factor Prices

Olivier Blanchard

Abstract

The paper starts from two sets of facts about Continental Europe. The first is the steady increase in unemployment since the early 1970s. The second is the evolution of the capital share, an initial decline in the 1970s, followed by a much larger increase since the mid 1980s.

The paper then develops a model of capital accumulation, unemployment and factor prices. Using this model to look at the data, it reaches two main conclusions:

The initial increase in unemployment, from the mid-1970s to the mid 1980s, was mostly due to a failure of wages to adjust to the slowdown in underlying factor productivity growth. The initial effect was to decrease profit rates and capital shares. Over time, the reaction of firms was to reduce capital accumulation and move away from labour, leading to a steady increase in unemployment, and a recovery of the capital share.

The reason why wage moderation, clearly evident in the data since the mid-1980s, has not led to a decrease in unemployment is that another type of shifts has been at work, this time on the labour demand side. At a given wage and a given capital stock, firms have steadily decreased employment. The effect of this adverse shift in labour demand has been to lead to both continued high unemployment, and increasing capital shares.

What lies behind this shift in labour demand? There are two potential lines of explanation. The first is shifts in the distribution of rents, away from workers, for example the elimination of chronic excess employment by firms. The second explanation points to technological bias: firms in

Continental Europe are introducing technologies biased against labour and towards capital.

This paper is a rewritten and abridged version of "The Medium Run", published in the Brookings Papers on Economic Activity [1997]. I thank John Simon and Petya Koeva for their excellent research assistance.

This paper was triggered by the juxtaposition of two sets of facts about Continental Europe:

- The first is the striking — and by now familiar — increase in unemployment, and is shown in Figure 1. The figure traces the behaviour of the unemployment rate in the three major Continental European countries, France, Germany and Italy, since 1970. Except for a small dip in the late 1980s, unemployment has steadily increased since the early 1970s, standing now above 10 per cent in all three countries.
- The second is less familiar but nearly equally striking, and is presented in Figure 2. The figure traces the behaviour of the share of capital in the business sector in the same three countries, since 1970. Capital shares, which had decreased in the 1970s, have increased steadily since, and stand now at their highest level in recent history. In France for example, the share of capital has increased from a low of 29 per cent of GDP in 1981 to a high of 40 per cent in 1995.

My initial intent was to focus on the behaviour of the capital share. But it became quickly clear that thinking about the factors behind the evolution of the share led to revisit the factors behind the evolution of unemployment. Thus, the paper became an attempt at explaining the joint behaviour of unemployment, capital accumulation and factor prices. A sketch of the story that comes out is the following:

The initial increase in unemployment, from the mid-1970s to the mid-1980s, was mostly due to a failure of wages to adjust to the slowdown in underlying factor productivity growth. The initial effect was to decrease profit rates and capital shares. Over time, the reaction of firms was to reduce capital accumulation and move away from labour, leading to a steady increase in unemployment, and a

Figure 1. Unemployment rates in France, Germany and Italy

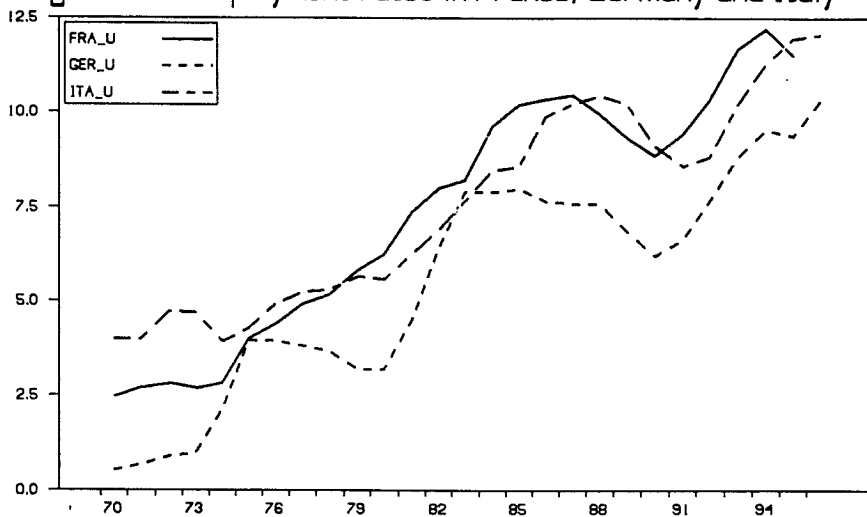
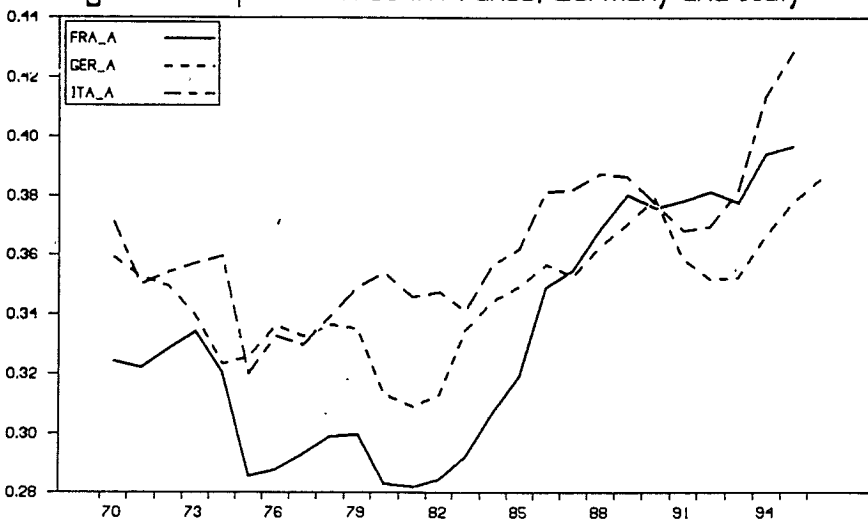

Figure 2. Capital shares in France, Germany and Italy



recovery of the capital share. That part of the story, which was already largely told by Bruno and Sachs [1985] in the mid-1980s, is familiar, and in its broad outlines, not controversial. It is the second part of the story which is new, and is likely to be more controversial.

Since the mid-1980s, wages have substantially decreased relative to underlying factor productivity. The reason why this wage moderation has not led to a decrease in unemployment is that another type of shifts appears to have been at work, this time on the labour demand side. At a given wage and a given capital stock, firms have steadily decreased employment. The effect of this adverse shift in labour demand has been to lead to both continued high unemployment, and increasing capital shares.

What lies behind this shift in labour demand? The paper does not answer that question. But, as a matter of logic, there are two potential lines of explanation. The first points to shifts in the distribution of rents: an explanation along these lines is for example that, over the last ten to fifteen years, firms have steadily reduced the chronic excess employment from which they suffered earlier in time. The second explanation points to technological bias: firms in Continental Europe have introduced technologies biased against labour and towards capital. Both interpretations carry however the same implication for the future. While the initial increase in profit rates has come so far with higher unemployment, the future should be brighter. As high profit rates trigger higher capital accumulation, employment should increase, and unemployment should decrease in the future.

The paper is organized as follows. In Sections I and II, I develop a simple model of unemployment and capital accumulation and use it to introduce three types of shifts — labour supply, labour demand and user cost shifts — and to describe their dynamic effects on the economy. In Sections III and IV, I turn to the data, focusing on one country, namely France. I construct time series for each of the three shifts, and show how, together, they can account for both the evolution of unemployment and the other major macroeconomic variables,

including the capital share. I then briefly describe results when the same methodology is used for other countries. In Section V, I list both tentative conclusions and a long list of open questions.

I. Labour Demand and Labour Supply

My purpose in this section is to introduce the simplest model of employment, unemployment and capital accumulation that will do the job, i.e. give a structure transparent enough to organize the discussion, yet rich enough to be taken to the data later on.

As a result of this choice, some shifts are taken as primitive, whereas they would be derived from deeper assumptions in a more theoretically ambitious model. In this sense, this paper is complementary to — but more modest than — two recent and related studies, the first by Phelps [1994] and the second by Caballero and Hamour [1997]. Both of these studies can be seen as trying to identify the potential factors behind the shifts I take as primitive. In contrast to those studies, this paper must be seen instead primarily as an exercise in organized data description.

The presentation of the model in the text is informal. A formal model, used both for simulations in the next section, and to construct and simulate the effects of the various shifts later, is presented in the appendix.

Short- and Long-run Labour Demand

Assume that production is characterized by a constant returns to scale production function, and Harrod-neutral technological progress:

$$y = f(k, an) \tag{1}$$

y is output, k is capital, n is labour. a is an index of the level of technology, and technological progress is assumed to be labour augmenting, so that a multiplies n . an is often called “labour in efficiency units.” As is well known from growth theory, the assumption

of Harrod-neutral technological progress is the only one that delivers balanced growth. Thus, it is a natural benchmark assumption here.

At any point of time, capital is given, and firms decide how much labour to employ. Ignoring for the moment costs of adjusting factor proportions — which I shall introduce below — assume that employment is given by:

$$a f_n(k, an) = (1 + \mu)w$$

This extends the standard first-order condition that marginal product equals the wage by allowing for a wedge between the two, parameterised by μ . Non-zero values of μ may come from imperfections in the goods and/or the labour market. For example, monopoly power in the goods market leads to positive values of μ (which, in this case, has the interpretation of a markup of price over marginal cost).¹ Or, taking an example from the labour market, featherbedding — firms being forced by unions to employ more workers than they would want at a given wage — will lead to negative values of μ : the product of the marginal worker will be lower than his wage.² In this paper, I shall take shifts in μ as primitives, leaving identification of the factors behind the estimated shifts below to future research.

Denote the ratio of labour in efficiency units to capital, (an/k) by x . The first order condition can be rewritten as:

$$f_n(1, x) = (1 + \mu) \frac{w}{a} \quad (2)$$

Given that $f_{nn} < 0$, the ratio of labour in efficiency units to capital, x , is a decreasing function of the wage in efficiency units, (w/a) . Solving for x gives:

$$x = x\left((1 + \mu) \frac{w}{a}\right), \quad x' < 0 \quad (3)$$

¹The analysis of goods markets in Phelps [1994] is aimed at explaining what factors may lead to changes in the markup, and through this channel, to changes in equilibrium unemployment.

²This is indeed the outcome in so-called “efficient bargaining” models. In these models, the marginal product of labour is set to the reservation wage of the worker. But the wage is a weighted average of the marginal and the average product of labour.

And employment, n , itself is given by:

$$n = \frac{k}{a} x \left((1 + \mu) \frac{w}{a} \right), \quad x' < 0 \quad (4)$$

This *short-run labour demand* relation is drawn as DD in Figure 3, for a given value of (k/a) . Employment, n , is measured on the horizontal axis, the wage in efficiency units, (w/a) on the vertical axis.

To this basic set-up, I add two sources of dynamics, which both capture important aspects of the data.

The first is costs of adjusting factor proportions. The production function (1) is best thought as representing the set of ex-ante substitution possibilities. Once firms have chosen specific machines, the scope for substitution is more limited. The most appealing way of formalizing this is through the explicit introduction of putty-clay technology (with positive elasticity of substitution only for new machines). A less conceptually appealing, but analytically simpler way, is to assume convex costs of changing factor proportions x . This is what I do here. This implies a vertical *instantaneous labour demand*, which, for a given capital stock, converges over time to equation (4) — rotates counterclockwise to converge to DD in Figure 3. Given this assumption, exogenous changes in wages lead initially to movements in the labour share in the same direction, independently of the elasticity of substitution in the production function (1).

The second is costs of adjusting the capital stock. A high profit rate triggers capital accumulation, a low profit rate to trigger decumulation. This takes place until the profit rate is equal to the user cost of capital. To derive the implications of this long-run condition, note first that the profit rate, i.e. profit per unit of capital, is given by:

$$\pi = f(1, x) - (w/a)x$$

Replacing x by its value from equation (3), we can express the profit rate as a function of w/a . For short, we can write:

$$\pi = \pi\left(\frac{w}{a}, \mu\right), \quad \pi_{w/a} < 0 \quad (5)$$

For $\mu = 0$, this is simply the “factor price frontier”, which says that the profit rate is inversely related to the wage in efficiency units.

Assume that the price of capital in terms of goods is equal to 1, that the depreciation rate is equal to δ and the interest rate equal to r . Then, in the long-run, it must be that:

$$\pi\left(\frac{w}{a}, \mu\right) = r + \delta \quad (6)$$

For a given r , the free entry condition pins down the wage (in efficiency units) in the long-run. If the wage is higher, then there is steady capital decumulation, and by implication, a steady decrease in employment; if lower, steady capital accumulation, and a steady increase in employment. In other words, the *long-run labour demand* is horizontal. It is drawn as the horizontal line in Figure 3.

A property that will prove useful below is that, around $\mu = 0$, small changes in μ have no effect on the profit rate.³ By implication, they have no effect on the wage consistent with zero net profit in the long-run, thus on the position of long-run demand.

Labour Supply

Think of “labour supply” as the relation between the wage set in bargaining between firms and workers, and labour market conditions.⁴

More specifically, let, for notational convenience, the labour force be equal to one, so that n stands for the employment rate, and for one minus the unemployment rate. Assume that labour supply is given by:

$$\frac{w}{a} = g(n, z), \quad g_n > 0, g_z > 0 \quad (7)$$

The wage (in efficiency units) is an increasing function of the employment rate (equivalently, a decreasing function of the unemployment rate), and of other factors, summarized in the variable z .

³This follows from the fact that π depends on μ only through its effect on x , and that, evaluated at $\mu = 0$, $d\pi/dx = 0$.

⁴Some readers may object to the semantics here, and prefer to call this relation the wage relation, or the wage-setting relation, of the supply wage relation. I find the use of “labour supply” to be a convenient short-hand.

Figure 3.

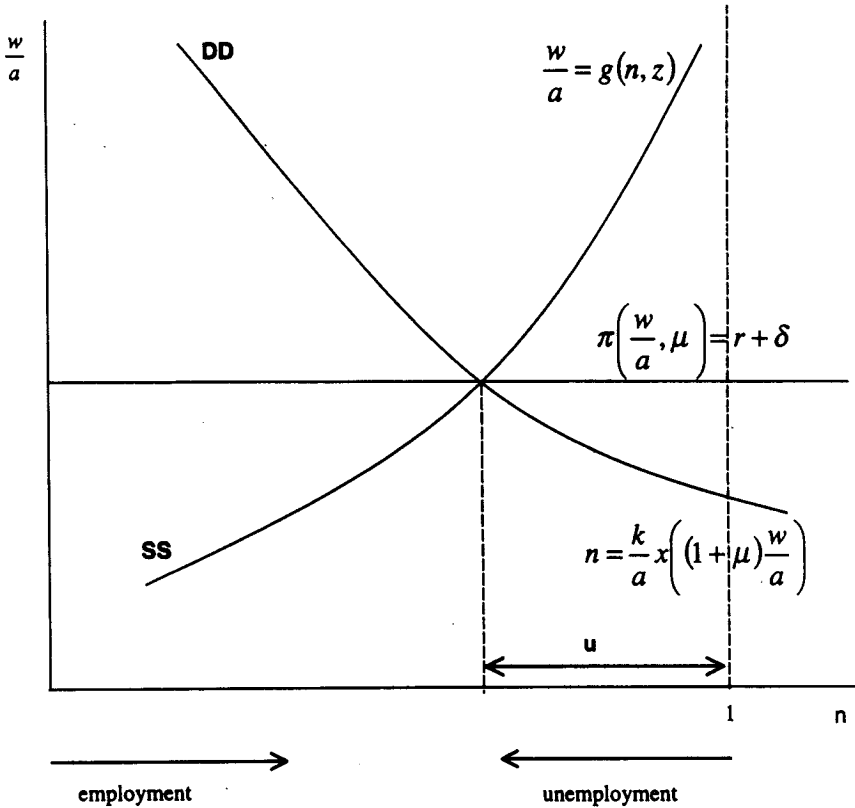

Much recent research has focused on the derivation of such a relation, and the many factors — bargaining structure, unemployment benefits, employment protection rules, and so on — that hide behind z .⁵ Just as for μ earlier, I shall take shifts in z as primitives in this paper, leaving to future research the task of linking the estimated shifts below to underlying shocks and changes in institutions. Let me however mention one point here. Note that, for given labour market conditions, the wage, w , is assumed in (7) to move one for one with the level of technology, a . Such a condition has to hold in the long-run if the unemployment rate is to be invariant to the level of technology. But it may not hold in the short run: if, for example, the bargaining wage fails to adjust to a slowdown in tfp growth for some time, this will show up as a positive value of z during that period of time. I shall return to this possibility below.

The labour supply relation is drawn as the upward sloping curve SS in Figure 3: the higher the employment rate (equivalently, the lower the unemployment rate), the higher the bargained wage.

The short-run and long-run labour demand and labour supply relations are drawn in Figure 3 so that they all cross at the same point: the economy is initially in the steady state associated with balanced growth. Over time, wages grow in line with technological progress; equivalently, wages in efficiency units are constant. Employment is constant (the labour force is assumed constant here). The unemployment rate, that we can measure starting from the right in the figure, is also constant. Capital grows at the same rate as labour in efficiency units, so that the ratio of labour in efficiency units to capital is constant. Absent shifts, technological progress does not affect unemployment.

⁵Much of the focus of Caballero and Hammour [1997] is precisely on the explicit derivation of this relation from bargaining between firms and workers, and on the role of changes in labour market institutions in affecting the relation between wages and labour market conditions.

II. Dynamic Effects of Labour Supply, Labour Demand, and User Cost Shifts

This section describes the dynamic effects of various shifts on the economy. The informal discussion is supplemented by simulations using the model developed and calibrated in the appendix. While a full description of the model and a discussion of the choice of the parameters is left to the appendix, it is useful to list the main features of the simulation model here:

- Production is characterized by a CES function, given by:

$$y = A((1 - \alpha)(an)^{\frac{\sigma-1}{\sigma}} + \alpha k^{\frac{\sigma-1}{\sigma}})^{\frac{\sigma}{\sigma-1}}$$

The elasticity of substitution σ is assumed equal to either 1.0 or to 2.0. α is chosen so as to imply an initial share of capital equal to 0.3. The depreciation rate is 10 per cent a year.

- The costs of adjusting factor proportions are chosen so as to imply a mean lag of adjustment (in response to permanent changes in factor prices) of about 5 years.
- The costs of adjusting capital imply a within-year elasticity of investment with respect to the shadow price of capital of 1.0.
- The real interest rate is fixed at 5 per cent, and independent of the demand for capital.
- The bargained wage is given by the relation $\log(w/a) = -\beta u + z$. The parameter β is taken to be equal to 1: an increase in the unemployment rate of a percentage point leads to a decrease in the wage of 1 per cent.

Labour Supply Shifts

Consider first an adverse labour supply shift, an increase in z . The reason may be a change in labour market institutions, such as an increase in the generosity of the unemployment benefits system. Or, as we discussed above, it may reflect a failure of wages to adjust to a slowdown in productivity growth: because we measure the wage in efficiency units on the vertical axis, such a failure of wages to adjust leads to an increase in the wage w relative to a , and thus an increase in (w/a) , at a given unemployment rate.

The dynamics of adjustment are depicted in Figure 4. The initial effect of the adverse labour supply shift is to shift the labour supply relation from SS to $S'S'$, up along the vertical instantaneous labour demand curve. Thus, the economy moves from point A to point B. There is no adjustment of quantities yet, and the increase in wages is reflected in a corresponding decrease in the profit rate and the capital share. This in turn triggers two dynamic responses:

Over time, firms adjust factor proportions, shifting away from labour, moving towards a lower labour-capital ratio. For a given capital stock, the labour demand curve tilts to converge to DD . This leads to both a decrease in employment and a partial recovery of the profit rate. If the elasticity of substitution is greater than one, this leads to a more than full recovery of the capital share.

Over time also, lower profit triggers capital decumulation, and thus a shift of the demand curve to the left, leading to both a decrease in employment and, through the effect of unemployment on wages, a decrease in wages. The decrease in wages also leads to a recovery of the profit rate and of the capital share.

Thus, both lower capital and a lower labour-capital ratio lead over time to lower employment, higher unemployment and a decrease in the wage: the effect of the initial wage push on the wage is steadily offset by the effect of higher unemployment. In the long-run, with an unchanged user cost, the profit rate must return to its initial value. This implies that the wage must return to its initial value as well.

Figure 4. Effects of an adverse labour supply shift

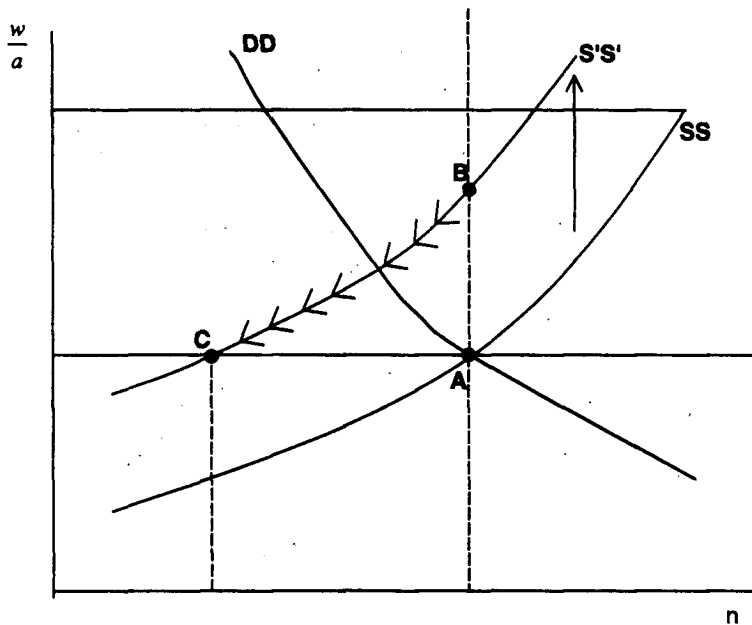

The economy ends up at point C.

In the new steady state, unemployment is higher: this higher unemployment rate is needed to offset the effects of the increase in z on the wage. But the labour-capital ratio, the profit rate and the wage rate are the same as before the shift, and so is the share of capital. The economy is basically operating in the same way as before, only at a lower level of activity for both labour and capital.

Figure 5 presents the results of the corresponding simulation. The shift is a permanent, unexpected, increase in z in year 5, from 0.0 to 0.1. The model is solved under rational expectations. The figure plots the evolution of the profit rate, the wage rate, the profit-wage ratio, the labour-capital ratio, the capital share and the unemployment rate, for two values of σ , 1.0 (continuous line) and 2.0 (dotted line). Both the wage and labour are measured in efficiency units.⁶

The figure shows the decline and the recovery of the profit rate and the capital share, together with the steady increase in the unemployment rate. It also shows how the labour-capital ratio initially goes down as wages are high, but then recovers as wages are forced down by higher unemployment.

The figure also allows us to examine an explanation that has been offered for the increase in capital shares since the early 1980s, namely that they may reflect the dynamic response to the earlier adverse wage shifts of the 1970s. This is indeed a logical possibility: if the elasticity of substitution is greater than one, then the initial decrease in the capital share following an increase in the wage will turn into an increase in the capital share as firms adjust factor proportions to reflect the underlying substitution possibilities. (In the long run, as the wage returns to its initial value, the share will also return to its initial value, whatever the elasticity of substitution. But this may take a long time.) At least for the parameters used for the

⁶Let me use the opportunity to correct a mistake in Blanchard [1997]. Figure 4 in that paper is the same as Figure 5 here, but incorrectly states the time unit as being a quarter, when it is in fact a year. The same remark applies to Figures 5 and 6 in that paper.

Figure 5. Effects of an Adverse Labour Supply Shift

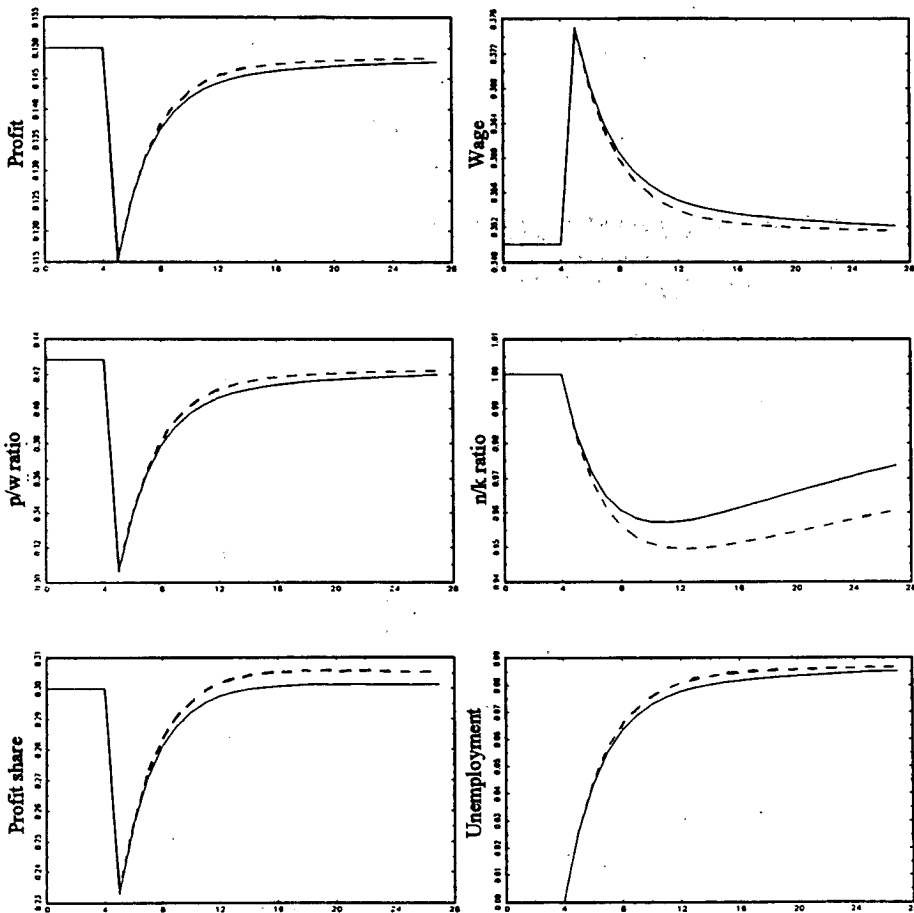

simulations, this hypothesis appears unlikely to play an important role empirically. The path of the capital share for $\sigma = 2$ shows indeed the share exceeding for some time its steady state value; but the path is barely distinguishable from the path corresponding to the case where $\sigma = 1$, and the degree of overshooting is small.⁷

Even at this crude stage of the analysis, it is clear that adverse labour supply shifts can potentially explain much of the early evolution of European unemployment from the mid-1970s on. They naturally explain why the share of capital first went down and then recovered, while unemployment kept increasing. But it is also clear that they do not naturally explain what happened after the mid-1980s, namely the increase in the share much above its 1970 level. This motivates looking at other shifts.

Labour Demand Shifts

Define an adverse labour demand shift as a decrease in x given (w/a) in equation (2), or equivalently a decrease in employment given (w/a) , k and a in equation (4). This shift may have one of two causes:

(i) It may come from an increase in the wedge between the marginal product and the wage, μ . I find the following example useful to think about, and probably relevant to the European experience. Suppose that firms had chronic excess employment, and are now willing and able to eliminate it. Why might this be? Perhaps because tighter corporate governance forces them to, perhaps because the unions are weaker and unable to enforce featherbedding. In terms of our model, this will lead to an increase in μ from an initially negative value to a value equal to zero.

(ii) The shift may come instead of a non Harrod-neutral shift in technology, leading firms to want to shift from labour to capital at a

⁷The assumption which plays an important role here is the assumption that the interest rate is given. If we were to assume instead an upward sloping supply of capital, an increase in z would lead to a higher wage in steady state, and, if the elasticity of substitution was greater than 1.0, an increase in the capital share in the long run. This points to the issue of the elasticity of capital supply both for an individual European country, and for Europe as a whole.

given wage in efficiency units.

To make things more concrete, think of firms as having a Cobb-Douglas production function:

$$y = k^\alpha (an)^{1-\alpha}$$

And think of an increase in α , the coefficient on capital.⁸ For given values of k , n and a , and thus a given value of $x = an/k$, the marginal product of labour will decrease (correspondingly, the marginal product of capital will increase); conversely, at a given wage, employment will decrease.

Assume first that the labour demand shift is due to an increase in the wedge μ , and for concreteness, think of it as coming from a reduction in featherbedding. The dynamic effects of such a shift are characterized in Figure 6.

For a given capital stock, and a given wage, firms want to reduce employment. Thus, the labour demand relation shifts to the left, from, say, DD to $D'D'$. Because of costs of adjusting factor proportions, this decrease in employment takes place only over time.⁹ Thus, the economy moves down from point A along the labour supply relation, and unemployment increases.

This reduction of employment triggers in turn two further adjustments, and both work to turn the initial increase in unemployment around. First, the elimination of excess employment increases the

⁸A while back, Houthakker [1956] showed how one could think of the Cobb-Douglas production function as the result of aggregation of Leontief functions, with the coefficients of the underlying functions being jointly Pareto-distributed. The same justification can be given here. New technologies are introduced that lead to a larger proportion of relatively capital-intensive methods of production, and thus, to an increase in the coefficient on capital in the aggregate production function.

⁹One may question the assumption that changing factor proportions is costly, whatever the cause. One may argue for example that removing featherbedding can be done much faster than changing factor proportions in general. Changing this assumption would change the dynamics, but not the qualitative implications emphasized below.

Figure 6. Effects of an adverse labour demand shift

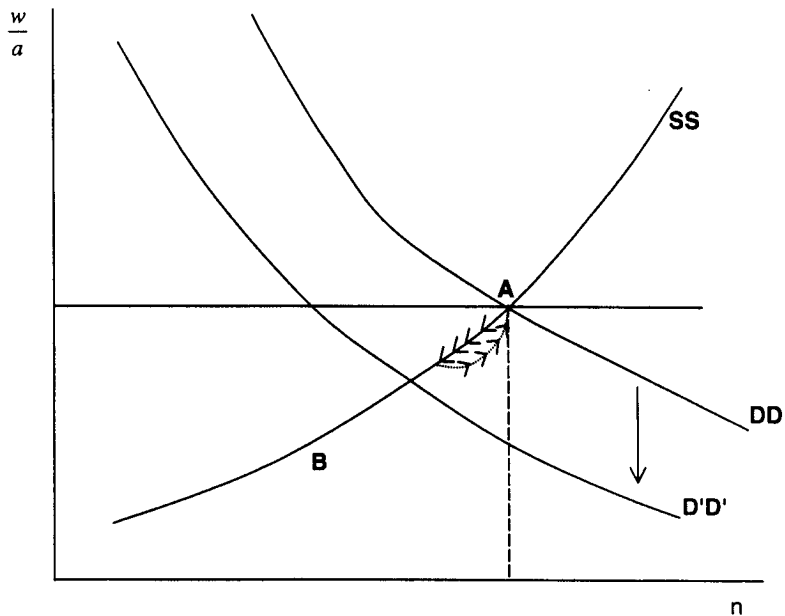

profit rate and the capital share. The increase in the profit rate in turn leads to capital accumulation, and thus to an associated increase in employment over time. Second, the increase in unemployment leads to a decrease in wages, and this decrease leads firms both to increase their labour-capital ratio, as well as to increase capital. Both of these effects lead also to more employment, and thus to an eventual decrease in unemployment.

Thus, after increasing initially, unemployment eventually turns around and starts decreasing. Where does the process end? We know from the previous section that, if we start close to $\mu = 0$, then, to a first approximation, the wage associated with zero net profit is unaffected by changes in μ . Thus, to a first approximation, the wage goes back to its pre-shift level, and the economy returns to point A. What happens at A is that while the labour-capital ratio is lower, the stock of capital is higher, leading to the same level of employment as before the shift. Given that the wage and the profit rate are the same as before, but the labour-capital ratio is smaller, the capital share ends up higher than it was before the shift.

Figure 7 shows the results of the corresponding simulation, in which μ increases unexpectedly and permanently by 0.1 in year 5, again for two values of the elasticity of substitution, 1.0 and 2.0.

The figure shows how such an adverse labour demand shift leads initially to both an increase in the unemployment rate and in the share of capital. It also shows how unemployment turns around and eventually returns to normal. The turnaround takes place however only eight years after the initial shift, and unemployment declines only slowly thereafter.

Figures 6 and 7 have shown the effect of an increase in the wedge, μ , on the economy. What if instead labour demand shifts come from bias technological change? The answer is that it makes very little difference. Firms initially move away from labour, leading to a decrease in employment. But over time, a higher marginal product of capital and a lower wage lead to capital accumulation, and an eventual increase in employment. The simulation results of a bias in

Figure 7. Effects of an Adverse Labour Demand Shift

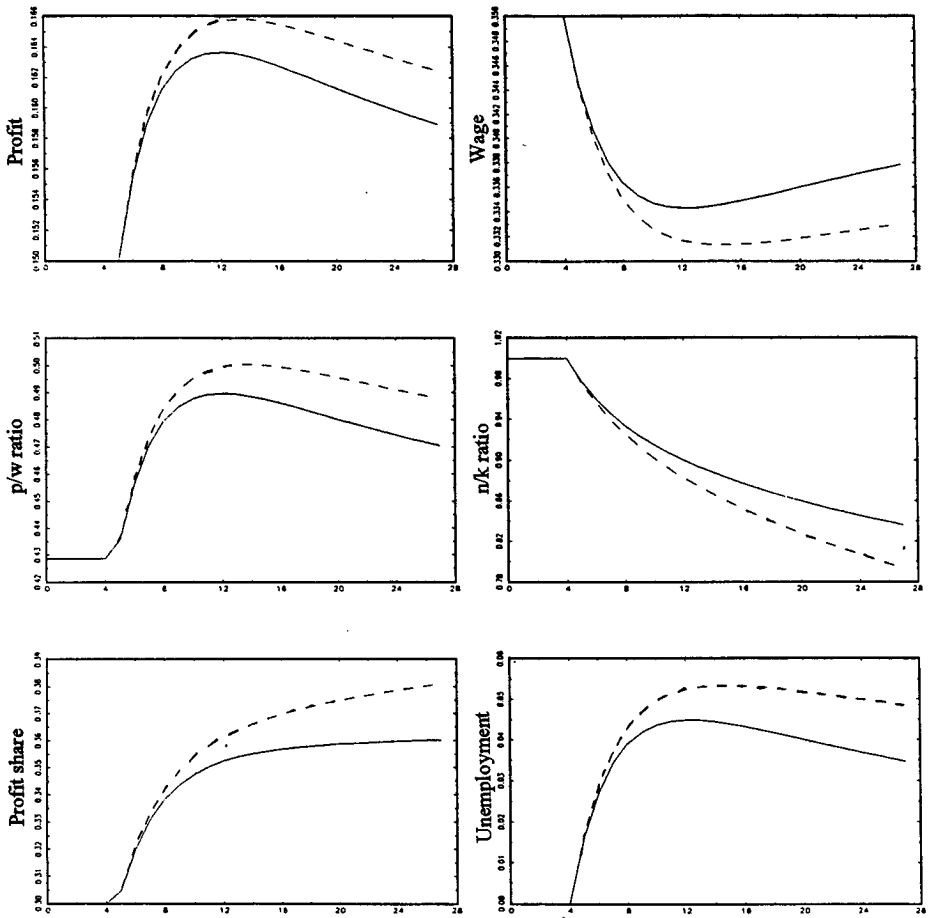

technology — parameterised by a change in the coefficients on capital and labour in the CES production function, decreasing the marginal product of labour relative to the marginal product of capital at a given labour-capital ratio — are nearly identical to those in Figure 7.

In summary, adverse labour demand shifts lead initially to an increase in unemployment and an increase in the capital share. Eventually, unemployment turns around, while the capital share remains permanently higher. This description suggests two tentative conclusions. Adverse labour demand shifts appear to be good candidates for the joint increase in unemployment and capital shares that has characterized Continental Europe since the mid-1980s. And, if this is right, they suggest a brighter future, where the initial period of labour shedding may eventually be replaced by capital accumulation and employment growth.

Shifts in User Cost

The third shift I look at is an increase in the user cost ($r + \delta$), coming from an increase in the interest rate.

This is done in Figure 8, and simulation results corresponding to an increase in the interest rate of 2 percentage points are shown in Figure 9. An increase in the user cost requires that firms eventually achieve a similar increase in the profit rate. This in turn requires a decrease in the wage associated with the zero net profit condition, a downward shift of the long-run demand relation.

Therefore the economy moves from point A to point B along the labour supply relation: employment decreases, and so does the real wage. Two sources of dynamics are at work behind the decrease in employment. First, the fact that the profit rate is now lower than the user cost leads to a decrease in capital over time. Second, and working in the opposite direction, the wage decline leads firms to increase their labour-capital ratio. The net effect is however unambiguously to increase unemployment (otherwise the wage would not decline in the first place). In the new steady state, at point B, the

Figure 8. Effects of an increase in user cost

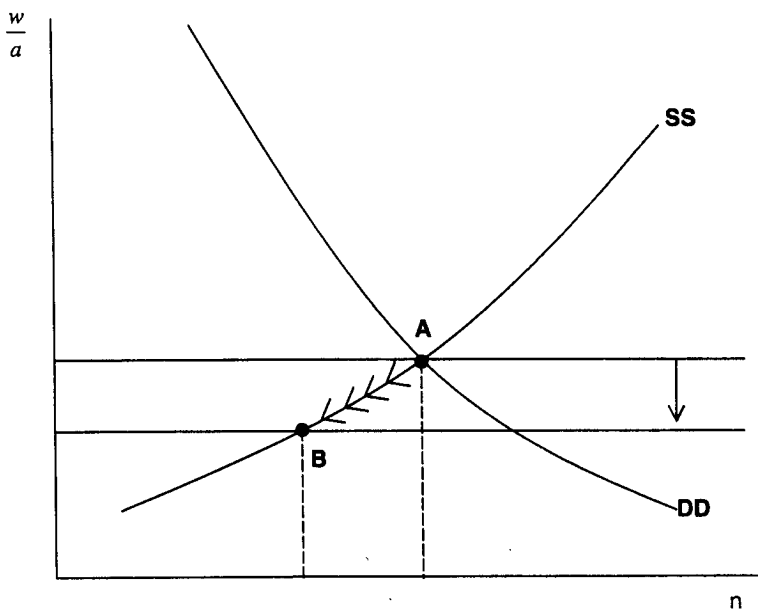
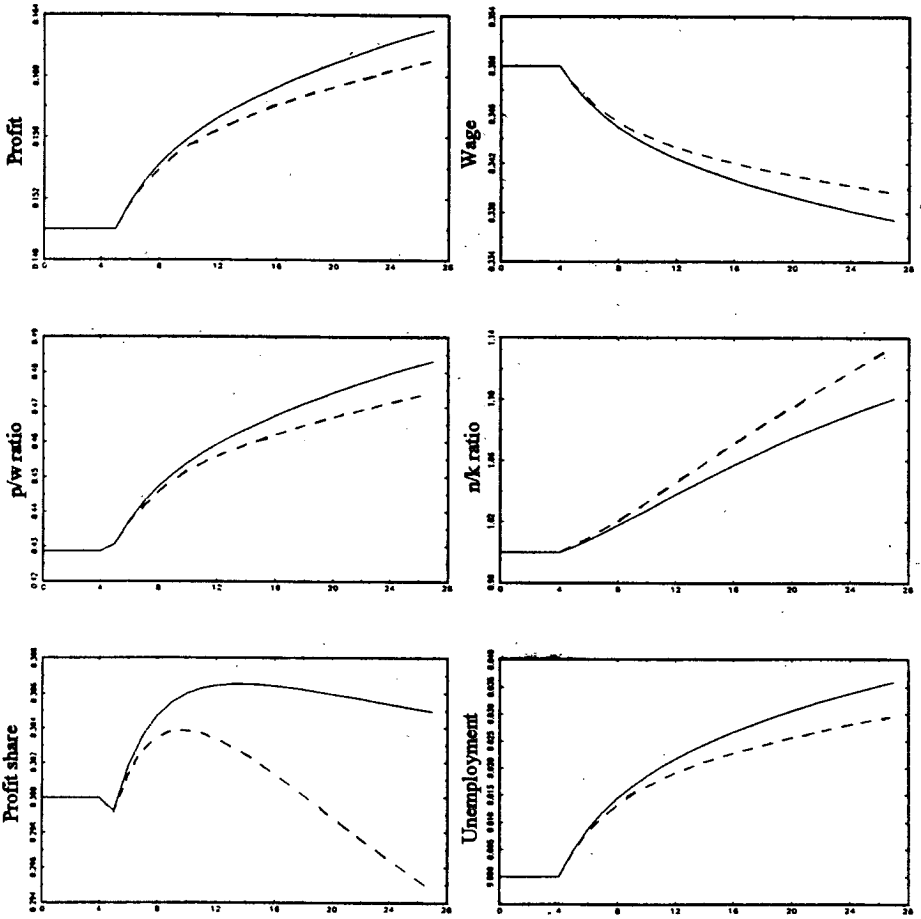

Figure 9. Effects of an Increase in User Cost



wage is now such that the profit rate is equal to the higher user cost. This is achieved through higher unemployment. Capital is lower, the labour-capital ratio higher.

Thus, a higher user cost leads to higher unemployment. Its effects on the capital share are however ambiguous, and depend on the elasticity of substitution between capital and labour in the underlying production function (1) (costs of adjusting factor proportions are, to a first approximation, irrelevant for the issue at hand). If the elasticity is equal to or larger than one — as most estimates of the long-run elasticity of substitution suggest — then the share of capital is lower in the new steady state (note that while the share appears to move a lot in Figure 9, the range of values on the vertical axis for the share is narrow. For $\sigma = 1$, the share moves by less than one percentage point). The simple point is that, while high interest rates surely explain part of the high European unemployment, they do not offer a natural explanation for the increase in capital shares since the mid-1980s.

III. Constructing the Shifts. The Case of France

How can we assess the role of these three shifts in the rise of European unemployment? One simple strategy is to construct them, using the relations of the model presented above, and then carry out a simulation of the model. This is what I do in this and the next section. Three remarks are in order before I start:

(i) I focus on one country, France. I do so partly because the evolution of both unemployment and the capital share are particularly striking, partly because this is a country I know well. But I have carried out the same exercise for 14 OECD countries (see Blanchard [1997]), and I summarize the results at the end of this section. Data for France and other countries correspond to the business sector only, and come from the OECD business sector data base, with minor adjustments described in Blanchard [1997].

(ii) I ignore potential deviations of actual unemployment from

equilibrium unemployment, coming from the interactions of shifts in aggregate demand and nominal rigidities. This is not because I believe that these are not relevant, but because, like Phelps [1994], I want to focus on the factors that affect equilibrium unemployment. This choice however carries a number of costs. The constructed series for total factor productivity below reflect in part variations due to cyclical variations, not true technological change (an issue familiar from the Real Business Cycle literature). Movements in unemployment due to deficient aggregate demand may be incorrectly attributed to labour supply or labour demand shifts.¹⁰ I plead guilty, hoping only that, for the medium run evolutions I want to focus on, these issues are less important than for the analysis of year-to-year fluctuations.¹¹

(iii) Constructing shifts is not as convincing as estimating them. But estimating them is much harder... Constructing them for alternative values of the parameters appears to be a useful first step.¹²

Constructing Labour Supply Shifts

To construct labour supply shifts, I start from the wage relation above:

$$\log\left(\frac{w}{a}\right) = -\beta u + z$$

¹⁰If for example a decrease in aggregate demand decreases employment leaving the wage unchanged, this will show up both as a combination of an adverse labour supply shift — the same wage at a higher unemployment rate — and an adverse labour demand shift — less employment, given capital and the wage.

¹¹Both the measurement of t_{fp} and of shifts could be improved to reduce these problems. T_{fp} could be measured better by taking into account the evolution of hours per worker, of capacity utilization. An attempt could be made at constructing an equilibrium unemployment series by using information about the change in inflation. I have not explored these adjustments at this point.

¹²In Blanchard [1997], I take the second step of estimating the shifts in labour demand by using time effects in a panel regression of 8 Continental European countries of the labour-capital ratio on a distributed lag of the wage in efficiency units. The implied shifts for France, obtained as the sum of the time effects plus the country-specific residuals for France, turn out to be very close to those constructed below using the benchmark parameters. This is obviously good news.

The first step is to construct a measure for a , the level of technology. To do so, I construct the Solow residual for each year, using the actual shares of labour and capital. I then divide it by the share of labour to obtain the corresponding rate of change of efficiency units. I then integrate this series over time and take the exponential to get the level of a .¹³ I construct the real wage w by dividing the cost of labour per worker (wage, fringe benefits, and labour taxes per worker) by the business GDP deflator. To get (w/a) , I then divide the real wage by the constructed series for a .

I choose a benchmark value of β equal to 1.0. For an unemployment rate of 10 per cent, this corresponds to an elasticity of the wage with respect to unemployment equal to 0.1, roughly the number estimated by Blanchflower and Oswald [1994] in their estimation of a "wage curve" for a number of countries. My work with Katz [1997] has led me to conclude that the right number may be higher. Thus, I also construct the series for z for $\beta = 2.0$, and for symmetry, also for $\beta = 0.5$.

Figure 10 shows the resulting series for z , with z constructed as $z \equiv \log(w/a) + \beta u$, for each of the three values of β . In each case, the series is normalized to equal zero in 1970. It is only the change since 1970, not the level which is relevant here.

All three series show a large increase in the early 1970s, with the wage increasing much faster than measured total factor productivity, a peak in the early 1980s, and a decline since then. Depending on the value of β , the value of labour supply shifts stands in 1996 between 1 per cent and 15 per cent. Put another way, wages in efficiency units are actually lower today in France than they were in 1970 (by about 6 per cent); but they would probably become too high

¹³As Hall [1990] has reminded us, the derivation of the Solow residual is correct only if the wedge between marginal product and the wage is equal to zero. If this wedge is different from zero, the computation must be modified to take account of the effect of the wedge on the shares. The results reported here are derived under the assumption that the wedge during the period was equal to one. I have also carried out the same exercise under the assumption that the wedge μ was equal to 0.2; the results are very similar.

Figure 10.

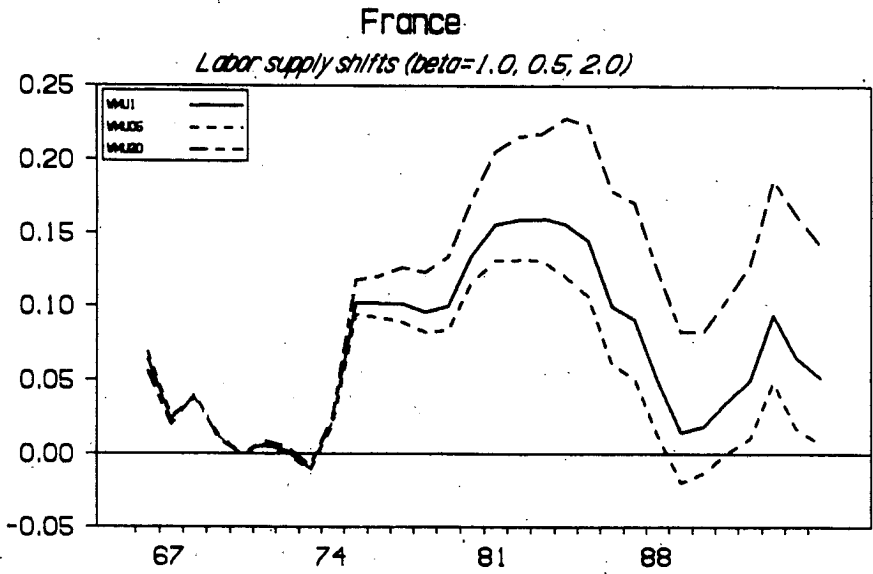

if unemployment decreased, putting upward pressure on wages. How high is “too high” depends on the assumed value of β , the effect of unemployment on the wage.

Constructing Labour Demand Shifts

In constructing labour demand shifts, I take them to be shifts in μ , the wedge between the marginal product and the wage; as will be clear below, if I were to interpret them as coming from technological bias, the constructed series would be identical, and as we discussed in the previous section, the simulation results would be nearly identical as well.

As we saw earlier, ignoring costs of adjusting the labour-capital ratio, the marginal product of labour is equal to the wage times one plus the wedge. Assuming that the production function is CES with elasticity of substitution σ , this relation takes the form:

$$\log\left(\frac{w}{a}\right) + \log(1 + \mu) = (ct + \log(1 - \alpha)) - (1/\sigma) \log\left(\frac{an}{y}\right) \quad (8)$$

where, because it will be useful below, the constant term on the right is decomposed in a term in α (the parameter in front of capital in the CES production function), and another term that depends on the parameters on the production function, but not on α .

Using this equation, given the time series for (w/a) and (an/y) , and given a value for σ , one can construct a series for $\log(1 + \mu_t)$, up to a constant term:¹⁴

$$\log(1 + \mu_t) = -\log\left(\frac{w}{a}\right)_t - (1/\sigma) \log\left(\frac{an}{y}\right)_t$$

This equation is correct however only in the absence of costs of adjusting factor proportions.¹⁵ If it is costly for firms to adjust those

¹⁴Note that under the additional assumption that $\sigma = 1.0$, the change in the log wedge is equal to minus the change in the log of the share of labour, a convenient fact for back-of-the-envelope computations. For example, a decrease in the labour share from 0.7 to 0.6 implies an increase in the wedge of roughly 15 per cent.

¹⁵For a detailed discussion of this and other issues of construction of the markup, see Rotemberg and Woodford [1998].

proportions, an increase in the wage will be associated with little contemporaneous change in (an/k) , and thus little change in (an/y) ; this in turn will lead to a decrease in the measured wedge. As I show in Figure 11a below, this is indeed what happens when the series for the wedge constructed using equation (8): the constructed series for the wedge turns out to be highly negatively correlated with the labour supply shifts constructed earlier and shown in Figure 10.

To take account of the dependence of factor proportions on the history of wages rather than just the current wage, I replace the current wage in equation (8) by a distributed lag of current and lagged wages. A more ambitious approach would have been to try to account for both past and expected future values of the wage, to use the first order condition for the firm relating factor proportions to both past and expected future factor proportions and to the current wage. I have decided to take this simpler and more transparent approach here. More specifically, I construct the time series for $\log(1 + \mu_t)$ (up to a constant) as:

$$\log(1 + \mu_t) = -\log(\tilde{w}_t) - (1/\sigma) \log \left(\frac{an}{y} \right)_t \quad (9)$$

where

$$\log \tilde{w}_t = \lambda \log \tilde{w}_{t-1} + (1 - \lambda) \log \left(\frac{w}{a} \right)_t$$

In line with the parameters chosen for the model earlier, I choose benchmark values of σ equal to 1.0 and a value of λ equal to 0.8, implying a mean lag in the adjustment of factor proportions to the wage of 4 years.

As an increase in μ corresponds to a decrease in employment for given k, a and w , I define a labour demand shift as the *negative* of the constructed series for μ .

The three series in Figure 11a correspond to three different values for λ , 0.0 (corresponding to no costs of adjustment), 0.8 (the benchmark value) and 0.9; in all three cases, σ is set equal to one. The three series are normalized to be equal to 0 in 1970. Under the

Figure 11 (a) and (b)

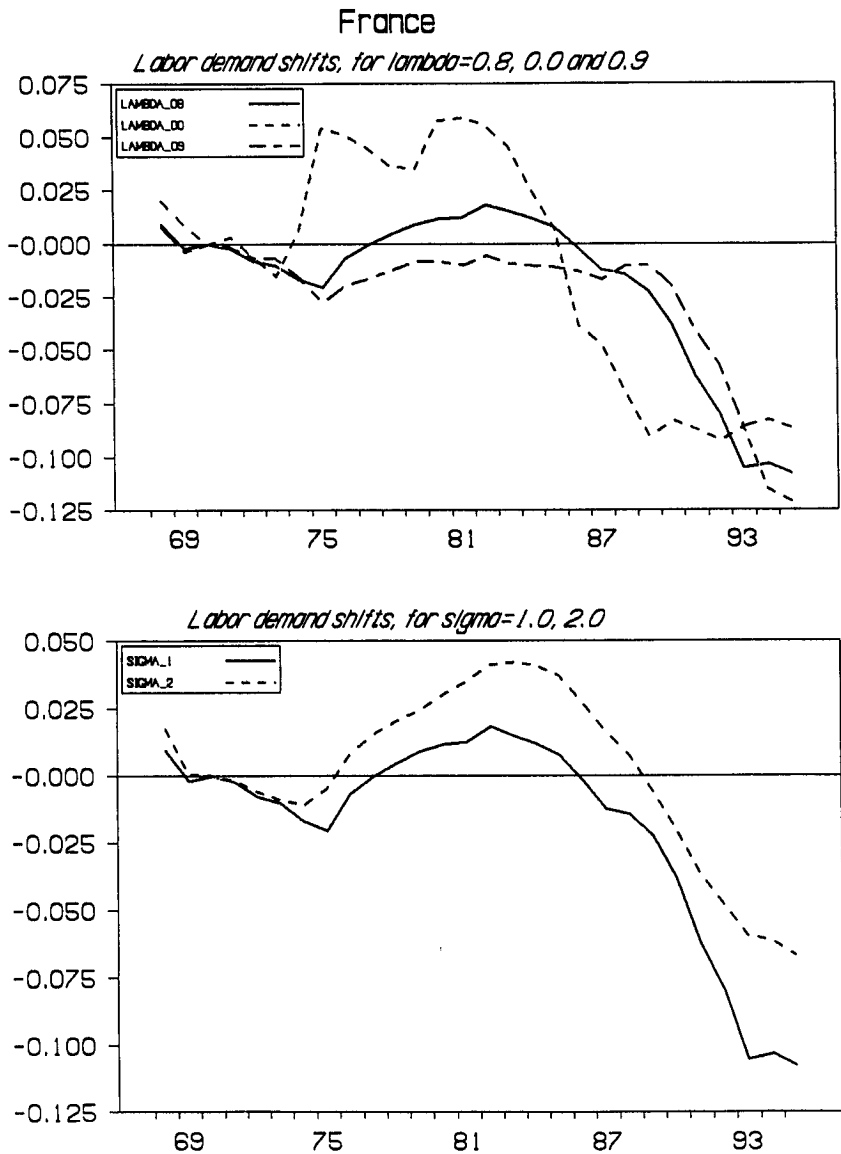

assumption of zero costs of adjustment, labour demand shifts are large and positive from the mid-1970s on, turning negative in the late 1980s. But, as the other two graphs show, the initial increase is largely spurious, coming from the slow adjustment of firms away from labour in the face of the wage push. For $\lambda = 0.8$, labour demand shifts are positive but small from the late 1970s on, and then turn negative from the late 1980s on. For $\lambda = 0.9$, they are basically equal to zero until they turn negative from 1990 on. Note that in all three cases, labour demand shifts are large and negative at the end; only the timing of the increase is affected by the value of λ .

The graphs in Figure 11b correspond instead to two different values of σ , 1.0 (the benchmark value) and 2.0; in both cases, λ is set equal to 0.8. The higher value of σ yields a more pronounced increase in the 1980s, and a smaller decrease at the end of the period.

These series for labour demand shifts have been derived under the assumption that they reflected shifts in the wedge, and that the production function was time invariant (up to Harrod neutral technological progress), so that, in particular $\log(1 - \alpha)$ was constant in equation (8). But the "wedge shifts" could equally have been called "technological bias shifts", changes in the coefficient α , with μ remaining constant. Equation (8) makes clear that, just looking at labour demand, changes in $\log(1 + \mu)$ and changes in $-\log(1 - \alpha)$ are observationally equivalent. Thus, we could equally describe the series in Figure 11 as showing technological bias in favour of capital and against labour — an increase in α — since some time in the mid-1980s.

Constructing User Cost Shifts

The user cost of capital in the model is given by $r + \delta$. To construct the time series for $r + \delta$, I use the depreciation ("scrapping") rate from the OECD data for δ . I construct r in three different ways:

In the benchmark series I use for simulations below, I construct r as equal to the long nominal interest rate on government bonds minus the average rate of inflation over the previous five years. The

resulting user cost series is denoted by "ucb5" in Figure 12. I also plot two alternative series in Figure 12. The first uses the nominal interest rate minus the inflation rate over the previous year, and is denoted by "ucb1". The second constructs the required rate of return as a weighted average of the real interest rate on bonds, constructed as the nominal interest rate minus a five-year average of inflation, and the required rate of return on equity, constructed as the sum of the dividend-price ratio plus a five-year average of past output growth (taken as an admittedly rough proxy for the expected rate of growth of dividends). The weights are 0.7 on bond finance, and 0.3 on equity finance. This third series is denoted by "ucbe" in Figure 12.

All three series in Figure 12 show a low user cost in the 1970s, a peak associated with disinflation in the early 1980s and another peak associated with German reunification and the "Franc fort" policy in the early 1990s. The user cost using lagged inflation rather than a five-year average is higher during most of the 1980s, and a little higher at the end. The user cost assuming bond and equity finance shows little trend and ends up lower than the other two: this is because the steady decrease in both the dividend-price ratio and the growth rate over the last 15 years imply a steady decrease in the estimated required rate of return on equity over the last 15 years.¹⁶

IV. Simulating the Model

Figure 13 shows the set of facts to be explained. It plots the evolution of six series: the profit rate, the wage rate per efficiency unit, the ratio of the profit rate to the wage rate (per efficiency unit), the ratio of labour (again in efficiency units) to capital, the capital

¹⁶In the computation of the user cost, I have ignored the trend decline in the relative price of capital, which is absent from the model above but is surely relevant empirically for a number of OECD countries. In France, this factor is not very important. The relative price of investment goods has decreased by only 6 per cent since 1970.

Figure 12.

France; User cost, assuming bond or bond and equity finance

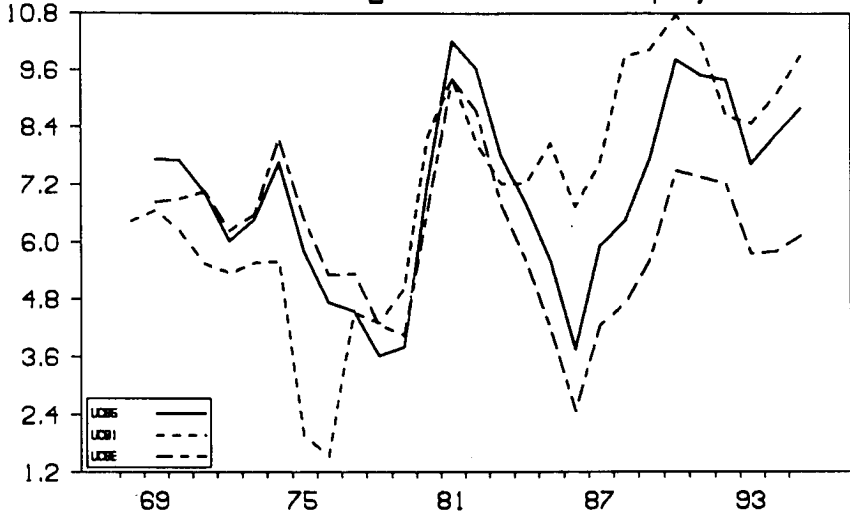
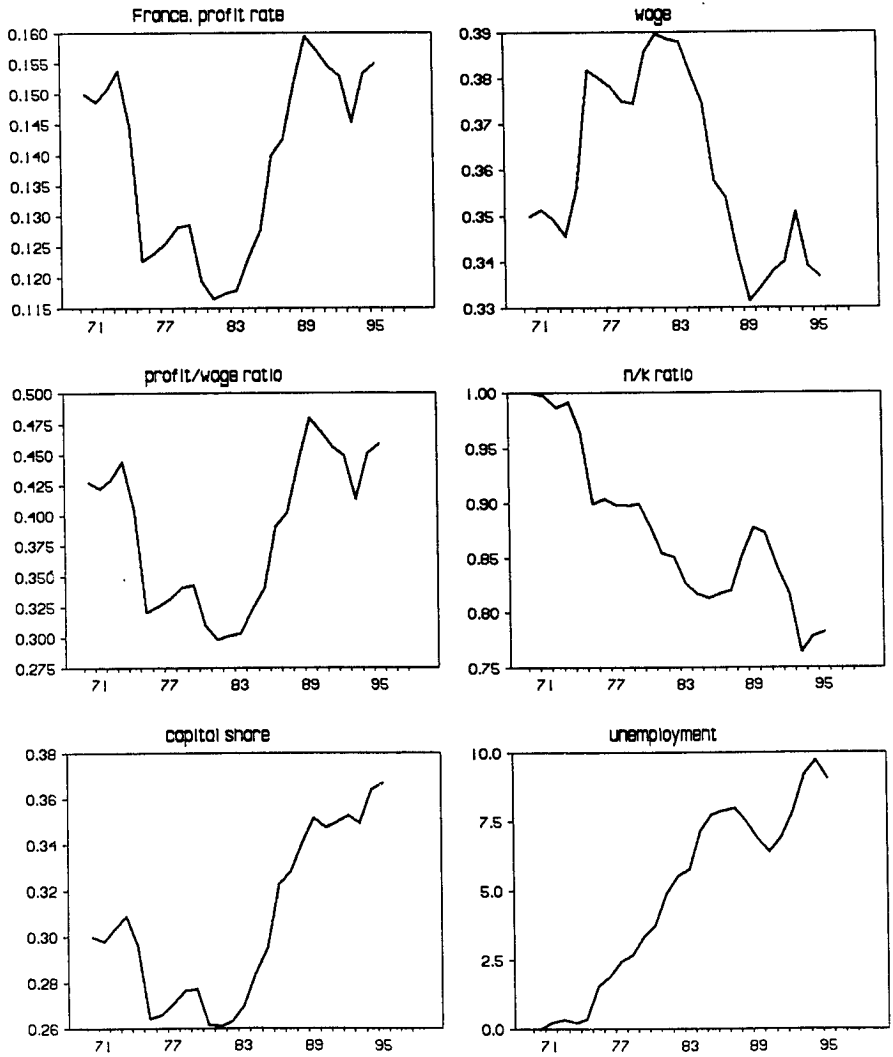

Figure 13. Facts to be Explained



share and the unemployment rate, for France, from 1970 to 1996. For ease of comparison with the simulations below, I normalize all the variables to have 1970 values equal to that of the steady state of the model; thus, in 1970, the profit rate is normalized to 0.15, the wage rate to 0.35, the ratio of the profit rate to the wage rate to 0.428, the labour-capital ratio is equal to 1.0, the capital share to 0.30, and the unemployment rate to 0.0. The basic evolutions are by now familiar, in particular the increase in the capital share, and the increase in unemployment.

All the simulations below assume zero values for the shifts pre-1970, and actual values thereafter. They are run under rational expectations, with expectations of future shifts at any point equal to current values of these shifts. Each figure shows simulation results under two alternative assumptions about σ , $\sigma = 1$ (the hard line), and $\sigma = 2$, the dotted line.

Figure 14 shows the results of a first simulation allowing for shifts in labour supply and in the cost of capital, but ignoring shifts in labour demand (wedge or technological bias shifts). It shows how the adverse labour supply shifts can explain the increase in unemployment, and the increase in the capital share up to the mid-1980s. But it shows how they are unable to explain the further rise in unemployment as well as the further increase in the capital share since the mid-1980s: as labour supply shifts decrease in magnitude, and lags of adjustment in adjusting factor proportions work themselves out, the labour-capital ratio turns around, leading to a counterfactual reduction in unemployment and in the capital share.

Figure 15 shows the effects of all three shifts combined. It shows how the adverse labour demand shifts since the early 1980s help account for the evolution of both unemployment and capital shares since then. Compared to the previous simulation, the labour-capital ratio keeps declining (as it does in the data) despite the fact that, with the decrease in labour supply shifts and the downward pressure from unemployment, the wage is now below its initial value.

Figure 14. Simulation Using Labour Supply and User Costs Shifts

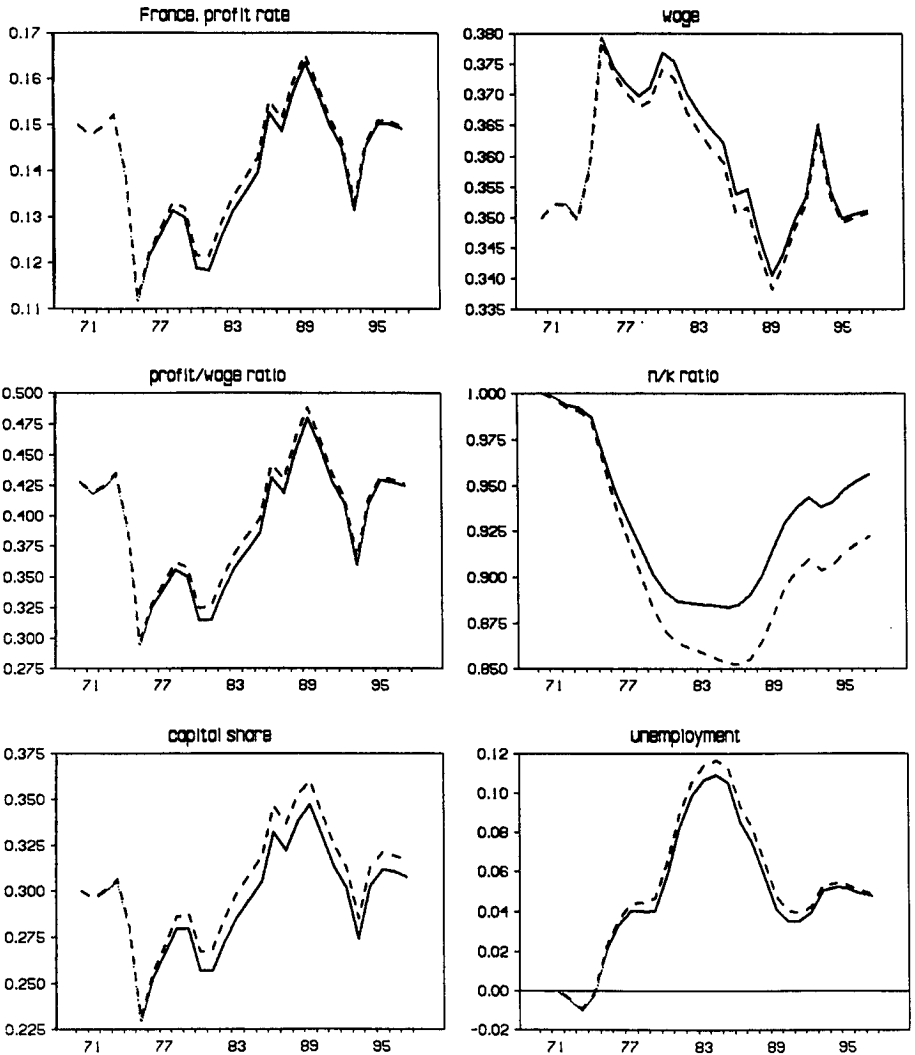
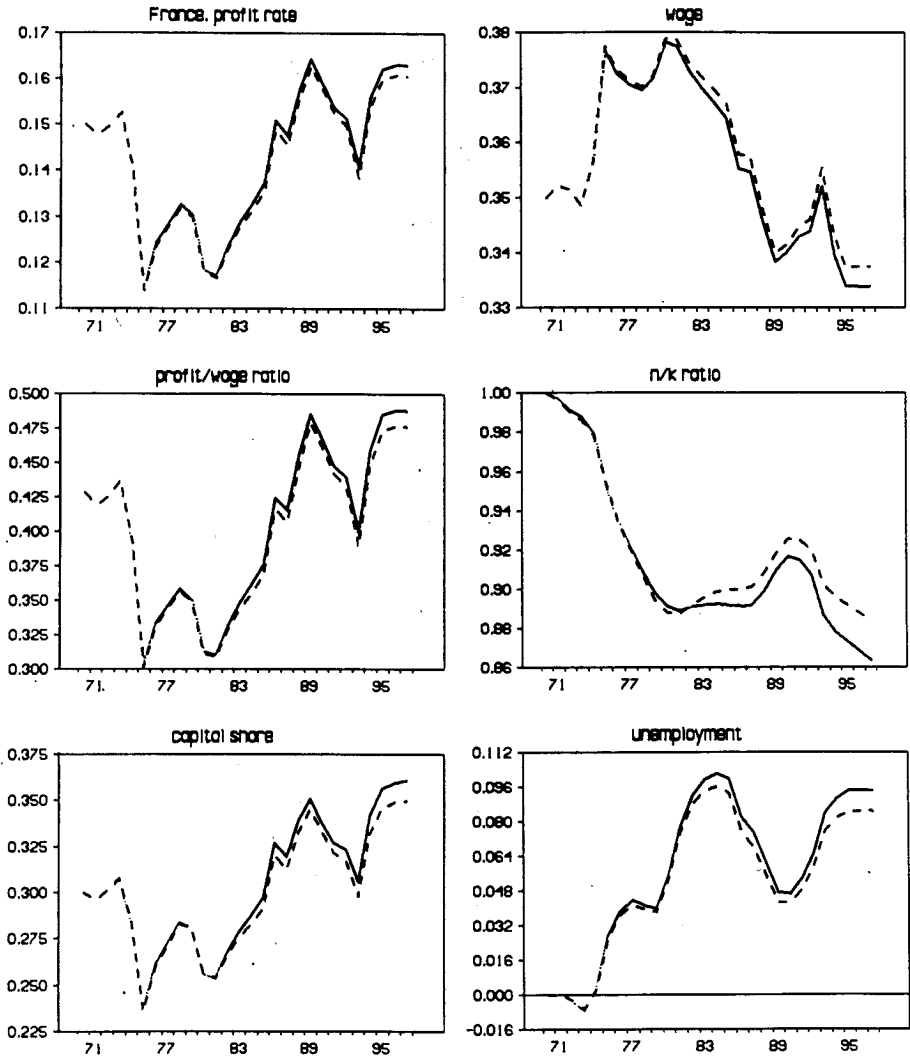

Figure 15. Simulation Using All Three Shifts



Unemployment remains high, and so does the capital share.¹⁷

Other Countries

In Blanchard [1997], I carried out a similar exercise for 13 other OECD countries. The limits of mechanically carrying out such an exercise are obvious. But the results were nevertheless revealing. I would summarize them as follows.

There is a clear distinction between two groups of countries. In a first group of countries, which I called "Anglo-Saxon countries" (the United States, the United Kingdom, and Canada), neither unemployment nor the capital share show much in the way of trends. And, especially for the United States, the constructed labour supply and labour demand shifts are small in amplitude throughout the period.

In the other group of countries, which — with a bit of geographic licence — I called Continental European countries (Australia, Austria, Belgium, Denmark, France, Germany, Ireland, Italy, Spain, Sweden), unemployment has typically gone up, and the share typically shows the U-shape pattern we documented for France, low in the early 1980s, and high today. In these countries, the period 1970-1981 shows large adverse labour supply shifts. The period since then is typically dominated by adverse labour demand shifts.

The simulation model is able to replicate the broad evolution of unemployment in many but not all countries. As we discussed earlier, when the fit is poor, this comes from the failure of the model to

¹⁷The fit between actual evolutions in Figure 12 and simulated evolutions in Figure 14 is obviously very good. This is however largely by construction, and cannot be seen as a test of the model. Recall that the series for the labour supply and demand shifts have been constructed so as to make the labour supply and the labour demand relations fit exactly. If the model had no internal dynamics, the fit would be perfect. To the extent that the model determines endogenously the dynamics of capital accumulation and factor proportions, the fit can still turn out to be poor. For France, the model fits the evolution of capital well, and thus the overall fit is good.

predict capital accumulation, and may thus come from an incorrect construction of the user cost, or of marginal profit, or because of the presence of shocks to the investment function. It may also come from our assumption that these economies were initially in steady state in 1970. In our model, an increase in the wage in efficiency units necessarily leads to an increase in unemployment. But in an economy which is catching up and not yet in steady state, an increase in the wage in efficiency units is what we would expect to observe on the adjustment path, and is consistent with constant unemployment.

Let me anticipate the question that you are likely to ask at this point. What do the shifts look like for Ireland, and how well does the model explain the evolution of unemployment and the capital share since the early 1970s?

How the shifts look is shown in Figure 16, which plots the labour supply, labour demand and user cost shifts since 1968 for Ireland, constructed in the same way as those presented earlier for France, under benchmark values for the parameters. Let me briefly focus on the first two.

There is evidence of adverse labour supply shifts until the mid-1980s, although less pronounced and taking place later than in France. Since the mid-1980s however, there has been a dramatic turnaround. The most likely explanation is the combination of the high rate of total factor productivity growth since then, together with wage growth in line with wage growth in the United Kingdom — an implication of the high degree of labour mobility between the two countries. The timing and the amplitude of the decline in adjusted wages since 1985 suggests that this shift may well be the main factor behind the Irish economic turnaround — more so for example than the often mentioned fiscal consolidation of the late 1980s.

As has been the case for France, the favourable effect of wage moderation on employment has been partly dampened by adverse shifts in labour demand. The evolution of labour demand shifts is similar to that of France, but smoother. The magnitude of the shift since the early 1980s is large, and similar to that of France. Again,

Figure 16.

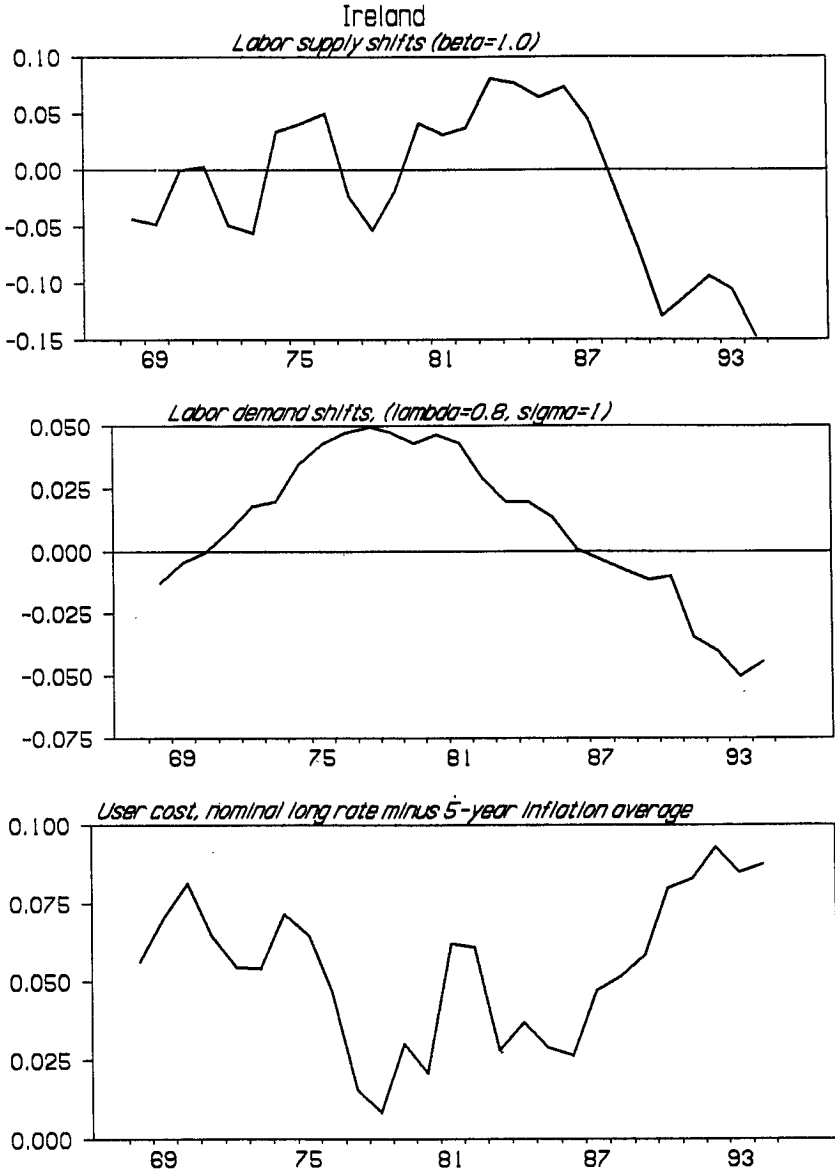

this evolution may reflect technological change biased against labour or the elimination of earlier chronic excess employment; whatever the cause, this shift has led to less of a decrease in unemployment and more of an increase in the capital share than would have been the case otherwise.

How does the model do in replicating the evolutions of unemployment and the capital share? Recall that unemployment increased from the late 1970s on to reach a peak of about 17 per cent in 1986, and has decreased since. The capital share (in the business sector), which — except for two short-lived dips in 1975-76 and 1980-81 — had remained around 20 per cent until the early 1980s, has increased, to reach 34 per cent today. The model accounts for the evolution of the capital share very well. It predicts however more of a decrease in unemployment since the mid-1980s than has been the case. The reason is, I believe, the assumption in the model that the labour force is fixed. In fact the increase in employment has triggered immigration to Ireland; this in-migration has partly offset the effect of higher employment on unemployment.

When used to forecast the future, the model yields optimistic conclusions. Favourable labour supply shifts, together with the favourable medium-run effects of adverse labour demand shifts lead to steadily decreasing unemployment. The logic is straightforward. I just hope the forecast is right...

V. Conclusions and Extensions

Let me briefly restate the main findings of the paper:

(i) Starting in the 1970s, most Continental European countries were affected by large adverse labour supply shifts — increases in wages in excess of underlying productivity growth, at a given unemployment rate. The initial effect of these shifts was to decrease profit rates and capital shares. Over time, the reaction of firms was to move away from labour, leading to a steady increase in unemployment and a recovery of capital shares.

(ii) Since the mid-1980s however, there has been substantial wage moderation, and labour supply shifts have decreased relative to their peak. But, since the mid-1980s also, they have been replaced by adverse labour demand shifts — decreases in employment by firms given capital and wages. These shifts explain why unemployment has remained high, and also explain the further rise in capital shares.

These findings have two obvious implications for the current debate on European unemployment:

(i) The nearly exclusive focus on “labour market rigidities” may be too narrow. If we think of labour market rigidities as leading to too high a wage (or, more generally, too high a cost of labour) for given labour market conditions, then, the conclusions above suggest that they are only part of the story, especially so since the mid-1980s. Indeed, one potential interpretation of the adverse labour demand shifts I have identified in this paper is that firms have been able to reduce chronic excess employment, either because of better governance or because of weaker unions. In that sense, part of the high unemployment rate may be due to the dismantling of some of these labour market rigidities.

(ii) They yield a cautiously optimistic message about future European unemployment. The logic of our model, and the results of simulations, suggest that, while adverse demand shocks lead to more unemployment initially, they lead to less unemployment later on. To return to the example in the previous paragraph, the elimination of chronic excess employment initially increases unemployment. But, by increasing profit, it leads to higher capital accumulation and higher employment in the future. These positive effects are still to come. But the logic of our argument suggests that, unless high user costs prevent them from leading to more capital accumulation, they may indeed be on the way.¹⁸

¹⁸In that respect, a worrisome aspect of the current French economic situation is that investment is low given current profit rates and sales: standard investment equations have shown large negative residuals for the past few years (INSEE [1998]). This suggests that there may be something else at work, which is not

The findings also raise a number of questions:

(i) The first comes from the sharp difference between Anglo-Saxon countries — especially the United States — and Continental countries. The proximate answer given by this paper for why the United States has been able to avoid steadily rising unemployment is that it had neither large adverse labour supply shifts early on, nor large adverse labour demand shifts later on... (The share of capital in the United States has remained nearly constant throughout the period.) Such an answer is clearly just a first step. Is this absence of measured supply and demand shifts due to different economic shocks in the first place — for example, a smaller decrease in total productivity growth in the 1970s — or is it due to a different response to these shocks, because of different labour market institutions? If adverse labour demand shifts in Europe have come from technological bias, why are firms in Continental Europe adopting different technologies from those in the United States? This takes us to the second set of questions: the sources of labour supply and labour demand shifts.

(ii) Identifying the source of the adverse labour supply shifts may be the easiest part as it builds on a very large body of research. There is a general consensus that the source of these shifts is to be found in the interaction of economic events — the increase in oil prices early on, the slowdown in total factor productivity growth, perhaps a shift in the relative demand for skills more recently — and labour market institutions — the social treatment of unemployment, employment protection, minimum wage legislation, and so on.¹⁹ One of the puzzles faced by previous research has been how to reconcile the fact that unemployment has remained high while oil price hikes have been more than reversed, workers' aspirations must by now have adapted to slower underlying productivity growth, unions appear to have become weaker not stronger, governments have started tightening social insurance programmes, and so on. The findings that labour supply shifts have indeed largely decreased, and that the persistence

captured in the model of this paper.

¹⁹For a useful survey, see for example Nickell [1997].

of high unemployment comes from labour demand shifts since the mid-1980s may offer a key to that puzzle.

Indeed, much of the econometric research on the increase in unemployment has taken the form of estimation across countries and time of a reduced-form equation for the unemployment rate as a function of a number of observable variables. This paper suggests a potentially more productive approach, that of identifying separately supply and demand shifts, and then trying to explain each of them separately.

(iii) Identifying the source of the more recent labour demand shifts is more difficult. In Blanchard [1997], I carried out a test based on a simple idea: if what has been at work is technological bias, we should have seen changes in the production function; if instead what has been at work is shifts in the distribution of rents, we should see no such changes. I thus looked for whether I could find shifts in the production function in the direction suggested by the evolution of shares. That test unfortunately was inconclusive, reflecting the general difficulty of precisely estimating production functions, and even more so, changes in production functions over time. The next step is, I believe, to look at cross-sectoral evidence, and to try to relate demand shifts to potential underlying causes, such as the estimated initial level of rents, the estimated initial degree of labour hoarding, the initial structure of bargaining and so on.

There may also be something to be learned from the cross-country evidence. Across the 14 countries I looked at, the cross-country correlation between the labour supply shifts from 1970 to 1981 and the labour demand shifts since 1981 is 0.40: countries which had larger adverse labour supply shifts in the 1970s have typically also suffered larger adverse demand shifts since. It is tempting to see this relation as causal. Firms in countries where labour supply shifts were stronger may have decided to adopt technologies that used less labour and more capital. The lags in introducing such technologies may be even longer than those involved in changing factor proportions within

the set of existing technologies.²⁰

This correlation between labour supply shifts and labour demand shifts also suggests a tentative explanation for the difference between Anglo-Saxon and Continental countries. The productivity growth slowdown was smaller in Anglo-Saxon countries, induced technological bias against labour has therefore been more limited. Put another way, smaller adverse labour supply shifts in Anglo-Saxon countries from 1970 to 1981 may explain why adverse labour demand shifts have also been more limited.

(iv) The last question is that of the relation of the shifts between labour and capital documented in this paper, and the shifts between skilled and unskilled labour documented in recent research in labour economics.

It is an intriguing fact that relative demand shifts between skilled and unskilled workers appear to have been particularly strong in Anglo-Saxon countries, and that relative demand shifts between labour and capital appear to have been particularly strong in Continental Europe. One wonders whether there may be an integrated explanation, whether what has happened in Anglo-Saxon countries has been a shift from unskilled to skilled labour, whereas Continental Europe has seen instead a shift from unskilled workers to capital.

Based on a preliminary look at numbers, it is not the case that the increase in the capital share in Continental Europe since the early 1980s has come primarily at the expense of unskilled labour. The data constructed by Laffargue and Saint-Martin [1997] for France for example imply that the decrease in the labour share from 68 per cent in 1982 to 58 per cent in 1990 has come from a reduction in the share of unskilled workers (defined as blue collar workers plus unskilled employees) from 10 per cent to 7 per cent, but also from a reduction of the share of skilled workers from 58 per cent to 51 per cent. In general, I interpret the data from France and other coun-

²⁰A number of recent papers tell stories of endogenous bias in technology adoption along broadly similar lines. See for example Zeira, [1997], and Acemoglu, [1997].

tries as suggesting two largely unrelated evolutions, a general and steady shift away from unskilled labour everywhere, and in Continental Europe, a shift away from labour as a whole since the early 1980s. A useful extension to this paper may be to carry out a similar exercise, but keeping track of three factors of production, skilled workers, unskilled workers, and capital.

VI. Appendix

A. The Model

The economy is composed of monopolistically competitive firms; the reason for introducing monopolistic competition is to explicitly derive the wedge between the marginal product of labour and the wage, and to be able to trace out the effects of changes in this wedge on the macroeconomy.

Each firm uses one unit of capital, which it combines with variable amounts of labour to produce output. The production function of a firm is given by:

$$y = f(1, x) \quad (10)$$

Harrod neutral technological progress can be introduced straightforwardly; all that is then needed is to measure labour and wages in efficiency units. I leave it out for notational simplicity.

The capital stock is thus equal to the number of firms in the economy, and changes in the capital stock correspond to entry and exit decisions of firms. A continuing firm makes only one decision at any point in time, that of how much labour to employ. Note that x is both employment in a given firm, and the labour-capital ratio for the economy as a whole.

Each firm is monopolistically competitive in the goods market. The demand for its good is given, in inverse form, by:

$$p = (y/\bar{y})^{-\gamma} \quad ; 0 \leq \gamma < 1$$

where p is the price charged by the firm relative to the price level, \bar{y} is average output, and γ is the inverse of the elasticity of demand. It follows from this constant elasticity specification that the gross markup of price over marginal cost charged by a firm is equal to $1 + \mu$ with $\mu \equiv \gamma/(1 - \gamma)$.

Each firm faces costs of adjusting its labour-capital ratio — equivalently its employment level. The cost of adjusting x to be given by $(c/2)(dx/dt)^2$, where c is a parameter.

Each firm faces a constant probability of death, δ , faces real interest rate r , and real wage (in terms of the price level) w . Under these assumptions, at any point in time, say time 0, the firm chooses employment so as to

maximize its value, given by:

$$v \equiv \int_0^{\infty} e^{-\int_0^t (r_s + \delta) ds} (\pi_t - (c/2) (dx_t/dt)^2) dt$$

where

$$\pi \equiv p y - w x$$

The first order conditions, together with the symmetry condition that all firms must charge the same price, so that $p = 1$, are then given by:

$$\begin{aligned} dx/dt &= (1/c) q \\ dq/dt &= (r + \delta) q - \pi_x \\ \pi_x &= (1/(1 + \mu)) f_n(1, x) - w \end{aligned}$$

Firms adjust the labour-capital ratio in response to the shadow price q . The second equation defines q as the present value of marginal profit. Marginal profit is equal to the marginal revenue product of labour — itself equal to the marginal product multiplied by the inverse of one plus the markup — minus the wage.

Once firms have adjusted the labour-capital ratio, the marginal product of labour must be equal to the real wage times one plus the markup μ (equivalently, the marginal revenue product of labour must be equal to the real wage). Denoting steady state values by a star, it follows from the previous three equations that:

$$f_n(1, x^*) = (1 + \mu) w^* \quad (11)$$

The evolution of the stock of capital comes from entry and exit of firms. To capture the slow adjustment of capital, I assume costs of adjustment for capital: the relative price of capital is an increasing function of the net rate of entry (equivalently, the net change in the capital stock). More specifically:

$$p_k = 1 + h dk/dt \quad (12)$$

where h is a parameter. Free entry implies that the following condition must hold:

$$v = p_k$$

If firms could freely choose their initial factor proportions, the model would yield a distribution of factor proportions across firms, with proportions depending on time of entry. To avoid such heterogeneity, I assume that new firms enter with the same labour-capital ratio as existing firms. This keeps the model tractable; but it also eliminates entry and exit of firms as one of the channels through which aggregate factor proportions could change over time.

The value of a new firm must be equal to the price of the machine needed to run it. From the definition of v earlier:

$$dv/dt = (r + \delta)v - (\pi - (c/2) (dx/dt)^2)$$

Entry takes place — equivalently the capital stock increases — when the value of an existing firm is greater than one. In steady state, $dv/dt = dx/dt = dk/dt = 0$ so that the previous equations imply;

$$\pi^* = p_k^*(r + \delta) = (r + \delta) \quad (13)$$

Profit per unit of capital is equal to the user cost.

This ends the description of the dynamic demands for capital and labour. The aggregate demand for labour is given by $n = kx$, the labour-capital ratio in each firm times the number of firms. I specify the supply of factors as follows:

I assume the real wage to be given by:

$$\log(w) = -\beta u + z \quad (14)$$

where β is the semi-elasticity of the wage with respect to the unemployment rate, and z is the labour supply shift.

I assume r to be exogenous. This is a strong assumption: it implies that the long-run supply curve of capital is infinitely elastic, and in combination with equation (13) it implies that the profit rate always returns to the same value $(r + \delta)$.

B. Functional Forms and Parameters

I choose functional forms and parameters as follows. The model is solved in continuous time but I think of the unit time period as a year and define parameters below accordingly. I take the production function to be CES, of the form (recall that each firm uses one unit of capital so that capital is there but equal to one in the production function):

$$y = A \left((1 - \alpha)x^{\frac{\sigma-1}{\sigma}} + \alpha \right)^{\frac{\sigma}{\sigma-1}} \quad (15)$$

I take the coefficient multiplying capital, α , to be 0.3, the multiplicative constant $A=0.5$. What happens to the capital share in the long-run in response to an increase in wages depends on the elasticity σ . The evidence in Blanchard [1997] and elsewhere points to a value of σ close to 1.0; I use 1.0 as the benchmark value. But to show how increases in wages can potentially lead to an increase in the capital share, I also examine the case where σ is equal to 2.0.

I choose the probability of death for firms — equivalently the depreciation rate for capital — δ , equal to 0.1, the real interest rate equal to 0.05. I take the initial value of γ to be equal to 0, corresponding to the case of perfect competition; this implies a value for the markup, μ , of 1.0.

I choose a value for c equal to 4.0. In a world in which production was strictly putty-clay, only the newly installed capital stock, thus roughly 10 per cent of the total capital stock each year, would embody the new desired factor proportions. This would imply a mean lag of adjustment of 4.5 years. Together with the other parameters of the model, a value of c of 4.0 implies that firms close each year roughly 17 per cent of the gap between desired and actual factor proportions. This in turn implies a mean lag of 4.8 years.

I choose a value for h equal to 10.0. This implies an elasticity of investment with respect to the relative price of capital, p_k , of 1.0. Empirical evidence on the relation of investment to “Tobin’s Q” yields lower elasticities, and thus higher implied values for h . But, as discussed in that literature, these estimates are likely to be upward biased. The instrumental variable approach used by Cummins *et al.* [1994] yields an elasticity of about 0.7.

I normalize the labour force to be equal to one. I choose z to be initially equal to 0.35; this value implies zero unemployment in the initial steady state. I choose a value of β equal to 1.0. For an average unemployment rate of 10 per cent, this corresponds to an elasticity of the wage with respect to unemployment equal to 0.1, roughly the number estimated by Blanchflower and Oswald [1994] for a number of countries. The evidence in Blanchard and Katz [1997] suggests that the elasticity is in fact lower in the short run, higher in the long run; I ignore these dynamics here.

The parameters and their implications for steady state values of output and other variables are given in Table 1. The model is solved using a Fair-Taylor algorithm.

Table 1. Parameters and steady state values.

Parameters		Steady state values	
σ (elasticity of substitution)	1.0,2.0	Output	0.50
α (coef on capital in prodn f.)	0.3	Employment	1.00
A (multiplicative ct in prodn f.)	0.5	Capital	1.00
δ (depreciation rate)	0.1	Wage rate	0.35
μ (markup)	0.0	Profit rate	0.15
r (interest rate)	0.05	Capital share	0.30
c (cost of adjusting n)	4.0	Unemployment	0.00
h (cost of adjusting K)	10.0		
β (elasticity of wage to N)	1.0		
θ (wage at zero unemp)	0.35		

References

- ACEMOGLU, D., 1997. Why do new technologies complement skills? Directed technical change and wage inequality, *mimeo*, MIT, June.
- BLANCHARD, O., 1997. "The medium run", *Brookings Papers on Economic Activity* (2), 89-158.
- BLANCHARD, O. and KATZ, L., 1997. "What do we know and do not know about the natural rate of unemployment", *Journal of Economic Perspectives* 11(1).
- BLANCHFLOWER, D. and OSWALD, A., 1994. *The wage curve*, MIT Press, Cambridge, MA and London.
- BRUNO, M. and SACHS, J., 1985. *The Economics of Worldwide Stagflation*, Basil Blackwell, Oxford.
- CABALLERO, R. and HAMMOUR, M., 1997. "Jobless growth: appropriability, factor substitution and unemployment", *Carnegie-Rochester Conference on Public Policy*, forthcoming, (*mimeo*, MIT, April 1997).
- CUMMINS, J., HASSETT, K., and HUBBARD, G., 1994. "A reconsideration of investment behavior using tax reforms as natural experiments", *Brookings Papers on Economic Activity* 2, 1-74.
- HALL, R., 1990. "Invariance properties of Solow's productivity residual", in P. Diamond (ed.), *Growth, Productivity, Unemployment*, MIT Press, Cambridge, pp. 71-112.
- HOUTHAKKER, H., 1956. "The Pareto distribution and the Cobb-Douglas production function in activity analysis", *Review of Economic Studies* 23(1), 27-31.
- INSEE, 1998. "Perspectives macroéconomiques à moyen terme", Di-

rektion des Études et Synthèses Économiques.

LAFFARGUE, J. and SAINT-MARTIN, A., 1997. Une simulation retrospective d'un modèle WS-PS pour la France de 1974 à 1993, *mimeo*, CEPREMAP and EUREQA, Paris.

NICKELL, S., 1997. "Unemployment and labor market rigidities: Europe versus North America", *Journal of Economic Perspectives* 11(3), 55-74.

PHELPS, E., 1994. *Structural Slumps. The modern equilibrium theory of unemployment, interest, and assets*, Harvard University Press; Cambridge MA.

ROTEMBERG, J. and WOODFORD, M., 1998. "The cyclical behavior of prices and costs", *Handbook of Macroeconomics*, forthcoming (*mimeo*, MIT, February 1997).

ZEIRA, J., 1997. Workers, machines, and economic growth, *mimeo*, Harvard, July.